



# Defender™ 5000X

Xtreme Rectangular Scales



## Smart Functionality, Durability, OHAUS Quality and Value

The OHAUS Defender™ 5000 Series is a feature-rich line of bench scales, combining a stainless steel D51XW indicator with a rectangular, painted steel base and a painted steel column. Ideal for shipping and receiving, production, packaging and general commercial and industrial weighing applications, the Defender 5000 offers a multifunctional indicator with multiple weighing units and software modes to meet the requirements of industrial and lab applications. With rugged steel construction, comprehensive yet intuitive software and multiple connectivity options, the Defender 5000 can meet the needs of demanding industrial operations.

### Standard Features Include:

- All steel construction with stainless steel indicator and painted steel column and base
- 5,000-7,500d default resolution
- NTEP certified resolution up to 1:3,000
- Quick display of results using large LCD with high-contrast white backlight
- Temporary display of 10x readability in weighing mode with quick key press
- Easy to operate with 4-key membrane keypad with raised tactile keys
- Weighs in one or more units: kg, g, lb, oz, lb:oz (decimal), metric tonnes and user-definable custom unit
- Multiple weighing modes including Counting, Percent Weighing, Dynamic/Animal Weighing, Checkweighing, and Display Hold.
- Internal universal switching power supply with hardwired line cord – optional NiMH internal rechargeable power pack available
- Includes RS232 interface with GMP/GLP data output including date and time
- Optional interfaces include DC relay control kit, AC relay control kit, 2nd RS232 and RS422/485

# Defender™ 5000X Xtreme Rectangular

## The Defender 5000 Offers Multiple Features and Easy Configuration:

To meet different operational needs, the Defender 5000 includes a suite of configurable software:

- Counting mode for packaging and inventory control, enabling counting into a container or out of a container for bulk operations. Supports a maximum counting resolution to 1:300,000 (minimum APW equal to 0.1d), selectable auto-optimization of average piece weight (APW). APW data can be displayed at any time using a quick key press
- Percent Weighing mode for formulation and mixing applications, with display of reference weight with quick key press
- Dynamic/Animal Weighing with selectable weigh times from 0-60 seconds
- Checkweighing function for packaging and weight checking, with display of results using LCD display and red/yellow/green LEDs. Audible beeper can be configured to prompt when weight is within range, under, over, or under or over range. Target weight values can be displayed at any time using a quick key press
- Display Hold mode for weighing large packages holds last stable weight on display until cleared
- The Defender 5000 weighs in one or more user-selectable units: kg, g, lb, oz, lb:oz (decimal), metric tonnes and user-definable custom unit
- Supports GMP/GLP data output with date, time user ID, project ID and scale ID. The Defender 5000 features selectable print options for data and print format
- To limit operator access to functions, the Defender 5000 offers both software lockouts for menu items as well as individual key functions

### Outline Dimensions

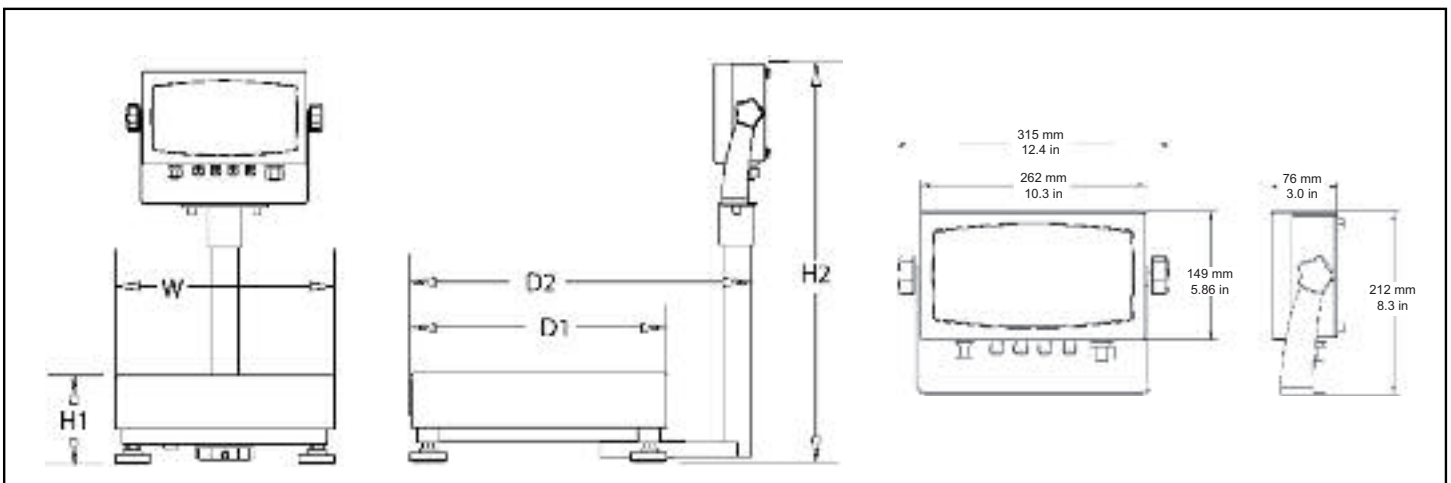

## Standard Features:

### Optional NiMH Battery

Allows for use in environments where an electrical outlet may not be readily available

### Internal Slot for Capacity Label

Protects label from the effects of moisture and external environments

### Stainless Steel 304 NEMA 4X/IP66 Enclosure

Indoor/outdoor protection against falling dirt, rain, sleet, snow, windblown dust, splashing and corrosion



### 3-Color LED Checkweigh Indication

with configurable beeper alert

### High-Visibility LCD Display

with bright white LED backlight and fast display stable weight within 2 seconds

### Included Table/Wall Mount Bracket

With large ergonomic adjustable knobs to maximize viewing angles.

### One-Key, Multiple Mode Selection

Counting, Dynamic Weighing, Display Hold, Percent Weighing and Checkweighing

### Hinged Front Cover

Only four sealing screws secure the housing for ease of servicing, while still ensuring IP66 seal integrity



### Stay Connected

Built in RS232 bi-directional interface and external input, optional RS485/422, optional second RS232 and optional AC or DC relay

### Universal Switching Power Supply

Automatically adapts to different voltages and frequencies; plug anywhere, anytime

### Painted Steel Columns

Available in both short and tall lengths

### Durable Base Frame Construction

Stainless steel pans and painted steel form-and-weld frames (R, L bases) provide maximum durability, rigidity and structural integrity. Load-unload cycle tested to ensure long-term performance.



### Fully Adjustable Feet

Four rugged, adjustable feet help prevent slippage on wet or uneven surfaces

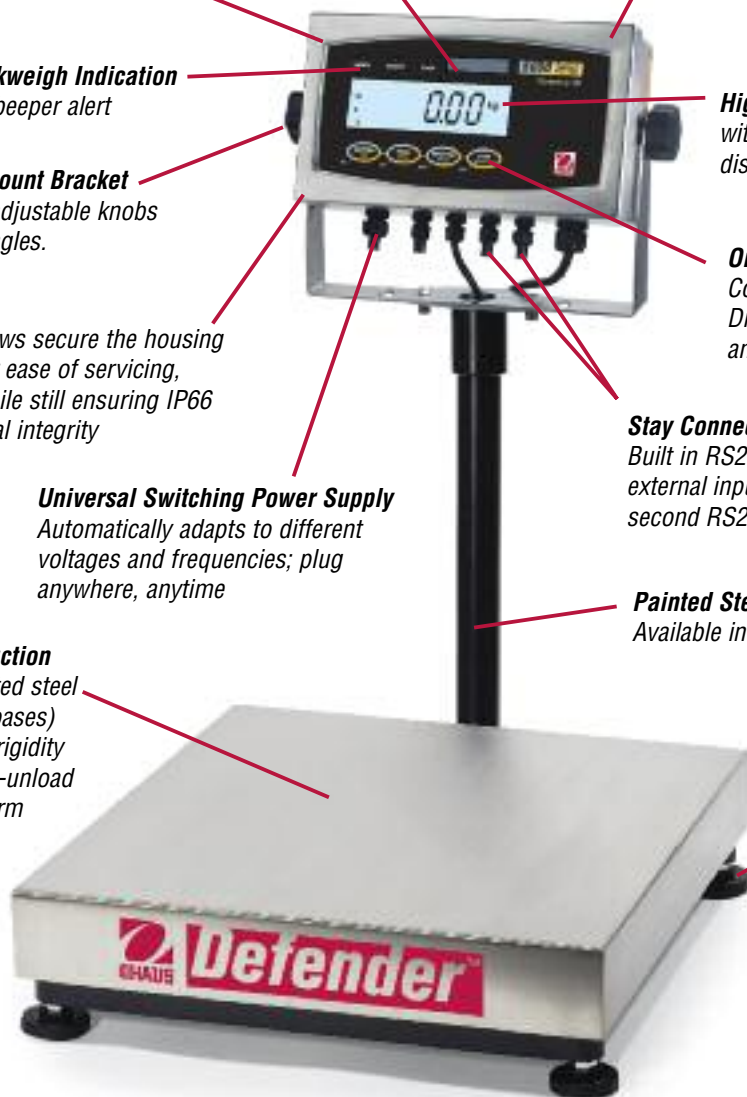

## Options and Accessories

### Interface Options

	OHAUS Number
AC Relay Kit.....	80500720
DC Relay Kit.....	80500727
RS422/485 Interface Kit .....	80500731
Second RS232 Interface Kit.....	80500733
Foot Switch .....	71173378

### Power Options

Rechargeable Battery Kit, T51P/T51XW.....	80500729
---	----------

### Other Accessories

	OHAUS Number
Compact Dot Matrix Impact Printer.....	80252042
Compact Thermal Printer.....	80251992
OHAUS Collect Software .....	80500746
TAL Software WinWedge .....	SW12W
Paper for Printer, 80252042 (1 roll) .....	80251932
Ribbon for Printer, 80252042 .....	80251933
RS232 Cable & Adapter, 80252042 Printer to T51XW.....	80252574
RS232 Cable, PC 9 Pin to T51XW .....	80500552
RS232 Cable, PC 25-pin to T51XW .....	80500553

# Defender™ 5000X Rectangular Scales

## Specifications

Model	D51XW15HR1	D51XW30HR1	D51XW60HR1	D51XW60HL2	D51XW100HL2	D51XW150HX2	D51XW300HX2
Capacity (max) x Default Readability (d)	30 lb x 0.005 lb 480 oz x 0.1 oz 30 lb : 0.1 oz 15 kg x 0.002 kg 15,000 g x 2 g	60 lb x 0.01 lb 960 oz x 0.2 oz 60 lb x 0.2 oz 30 kg x 0.005 kg 30,000 g x 5 g	150 lb x 0.02 lb 2,400 oz x 0.5 oz 160 lb : 0.5 oz 60 kg x 0.01 kg 60,000 g x 10 g	250 lb x 0.05 lb 4,000 oz x 1 oz 250 lb : 1 oz 100 kg x 0.02 kg 100,000 g x 20 g	300 lb x 0.05 lb 4,800 oz x 1 oz 300 lb : 1 oz 150 kg x 0.02 kg 150,000 g x 20 g	600 lb x 0.1 lb 9,600 oz x 2 oz 600 lb : 2 oz 300 kg x 0.05 kg 300,000 g x 50 g	
Maximum Displayed Resolution	1:7500	1:6000	1:7500	1:5000	1:7500	1:6000	
NTEP Capacity (max) x Certified Readability	30 lb x 0.01 lb 480 oz x 0.2 oz 15 kg x 0.005 kg 15,000 g x 5 g	60 lb x 0.02 lb 960 oz x 0.5 oz 30 kg x 0.01 kg 30,000 g x 10 g	150 lb x 0.05 lb 2,400 oz x 1 oz 60 kg x 0.02 kg 60,000 g x 20 g	250 lb x 0.1 lb 4,000 oz x 2 oz 100 kg x 0.05 kg n/a	300 lb x 0.1 lb 4,800 oz x 2 oz 150 kg x 0.05 kg n/a	600 lb x 0.2 lb 9,600 oz x 2 oz 300 kg x 0.1 kg n/a	
Maximum Certified Resolution	1:3000	1:3000	1:3000	1:2000	1:3000	1:3000	
Indicator Model	T51XW						
Column	13.8 in / 350 mm painted steel			26.8 in / 680 mm painted steel			
Construction	Stainless steel indicator, removable weighing platform, painted steel column and base construction, aluminum loadcell						
Safe Overload Capacity	150% of maximum capacity						
Protection	NEMA 4X/IP66 for indicator, IP67 for loadcell						
Weighing Units	lb, oz, lb:oz, kg, g, metric tonnes, custom unit						
Modes	Static Weighing, Dynamic Weighing, Counting, Checkweighing, Percent Weighing, Display Hold						
Display	1 in / 25 mm high 6-digit, 7-segment bright white backlit LCD						
Keyboard	4-button membrane switch						
Stabilization Time	Within 2 seconds						
Auto-zero Tracking	Off, 0.5, 1 or 3 d						
Zeroing Range	2% or 100% of capacity						
Calibration	Span: 1kg or 1lb to 100% of capacity / 3-point linearity (0 - 50% - 100% fixed)						
Power	100-240 VAC / 50-60Hz internal universal power supply						
Interface	RS232 and external input						
Operating Temperature Range	14°F to 104°F / -10°C to 40°C						
Scale Dimensions (W x H1 x H2 x D1 x D2)	12 x 3.7 x 23.6 x 14 x 18.7 in 305 x 95 x 600 x 355 x 475 mm			15.7 x 4.1 x 37 x 19.7 x 24.4 in 400 x 105 x 940 x 500 x 620 mm		16.5 x 4.9 x 37 x 21.7 x 26.4 in 420 x 125 x 940 x 550 x 670 mm	
Shipping Dimensions (L x W x H)	19.3 x 16.1 x 17.3 in 490 x 410 x 440 mm			29.1 x 27.2 x 9.1 in 740 x 690 x 230 mm		29.5 x 30 x 9.1 in 750 x 710 x 230 mm	
Approx. Net Weight	28.4 lb / 12.9 kg			52.2 lb / 23.7 kg		64.1 lb / 29.1 kg	
Approx. Shipping Weight	33.3 lb / 15.1 kg			59.5 lb / 27 kg		70.7 lb / 32.1 kg	

## Features

**T51XW:** Stainless steel water resistant NEMA 4X / IP66 housing, integral faceplate supports for easy servicing, backlit LCD weight display, checkweighing indication (green, yellow, red), membrane keypad with raised tactile keys, built-in bi-directional RS232 with manual/continuous/interval printing, external tare input, hardware configuration lockout switch, internal switching power supply with hardwired cord.

## Other Features

Zero point calibration, calibration test, span or linear calibration, selectable auto-zero tracking range, selectable stability range, selectable averaging level, selectable LCD backlight, selectable auto shutoff, retain zero weight data after power-off, Geo gravity adjustment, selectable key beep, key function lock, menu lock, selectable power-on and calibration unit, battery status display, display of gross/net weight, indication of stability, center of zero, over and underweight, overload and underload conditions. Configuration menus for PRINT1, PRINT2, COM1, COM2, and I/O.

## Compliance

- NTEP certified (CC No. 08-039 for indicator; 01-048A1 for bases)
- **Safety and EMC:** cUL<sub>US</sub> 2005/95/EC low voltage directive: EN60950-1:2001, FCC Part 15 Class A 2004/108/EC EMC directive: EN61326-1:1997; +A1:1998; +A2:2001; + A3>2003
- **Other:** Compliant to Directive 2002/96/EC on waste electrical and electronic equipment (WEEE)
- **Quality:** Ohaus quality management system registered to ISO 9001:2000

## OHAUS CORPORATION

\* 19A Chapin Road  
P.O. Box 2033  
Pine Brook, NJ 07058 USA

Tel: 800.672.7722  
973.377.9000  
Fax: 973.593.0359

www.ohaus.com

With offices throughout Europe,  
Asia, and Latin America

\* **ISO 9001**  
Registered Quality Management System

80774413\_A © Copyright Ohaus Corporation

